

The Complete System

Slot Drain

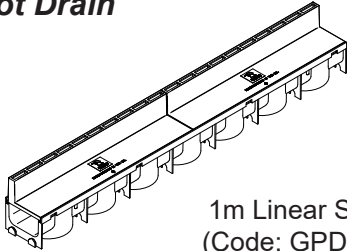

1m Linear Slot Drain
(Code: GPDST-1000)
(Black)

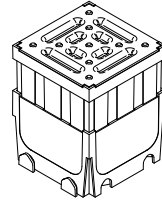

Junction unit
(Code: GPDST-JU)
(Black)



Leaf Trap

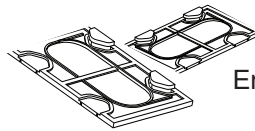

End Caps

Accessory Pack: 2 x End Cap and 1 x Leaf Trap (code: GPD-AP)

Also available: The SmartDrain channel (Code: GPD-1000)



BS EN 1433:2002

13

EN 1433:
2005-09

21

Drainage channel **Type M** for the collection and conveyance of surface water from areas which can only be used by pedestrians and pedal cyclists.

Strength Class:

A 15 in accordance with the manufacturer's installation instructions.

Channel Material:

Polypropylene

Grating Material:

Polypropylene

Dimensions:

(L) 1,000mm (W) 119mm (H) 88mm

Weathering

Resistance:

NPD

Load Testing:

UKCA: BRE Test No. 289 099

CE: KIWA Test No. 21DE-01886OR01

Other products from the Manthorpe Range include Cavity Trays, Cavity Closer, Loft Doors, Roof Ventilation, Through Wall Ventilation, Joist Seals and Dry Roofing Products.



Manthorpe Building Products Limited

Manthorpe House, Brittain Drive, Codnor Gate Business Park, Ripley, Derbyshire DE5 3ND

T: (01773) 303 000 F: (01773) 303 300 E: mbp.care@manthorpebp.co.uk

W: <http://www.manthorpebp.co.uk>

Manthorpe

SlotDrain

Fixing Instructions

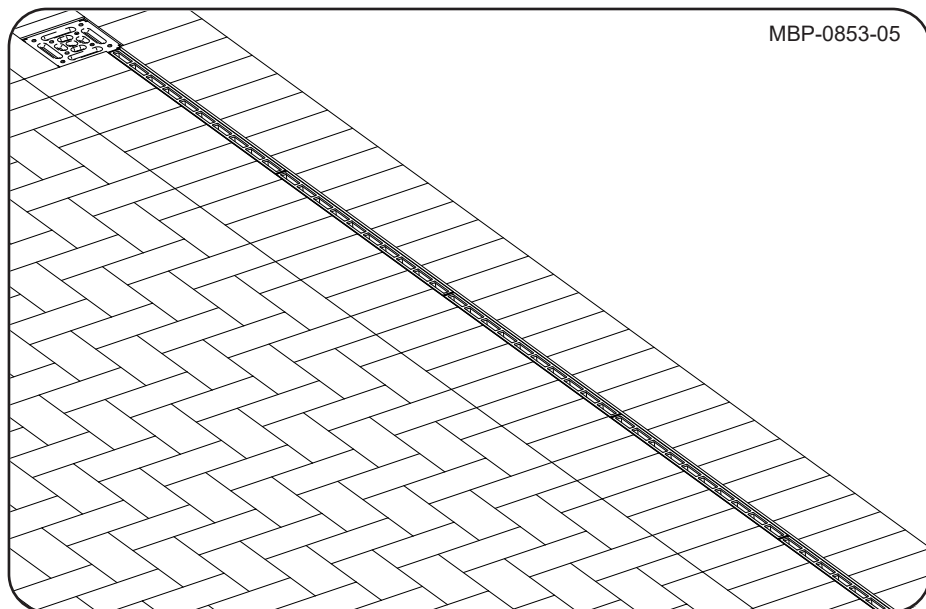

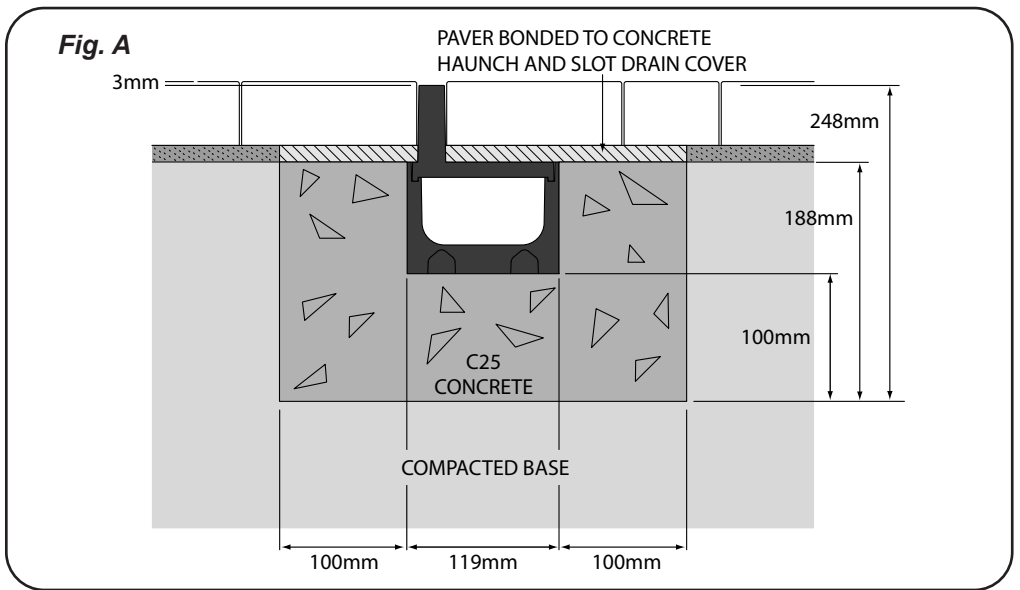

Important:

The top of the channel should lay 3mm below the top level of the paving material, take time before carrying out installation to correctly calculate the trench width and depth as detailed above in Fig A.

A fall of 1 in 40 (25mm in 1m) will guide water to the outlet at a substantial rate to avoid pooling and debris sticking.

It may be necessary to shorten lengths of SlotDrain during installation. If this is the case, use a handsaw and where possible, make the cut next to a rib on the channel to maintain the clip detail. Joints between channels should be sealed with a suitable silicon or polysulphide sealant.

Installation:

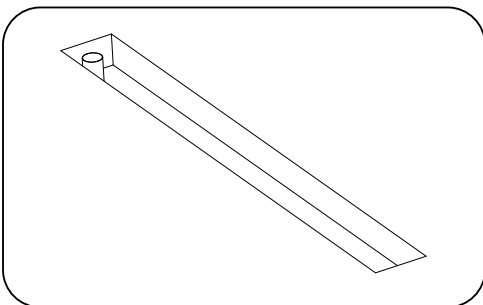

1. With an appropriate connection to a drain and a silt trap installed, dig a trench which is sufficient in length, depth and width for the required application.

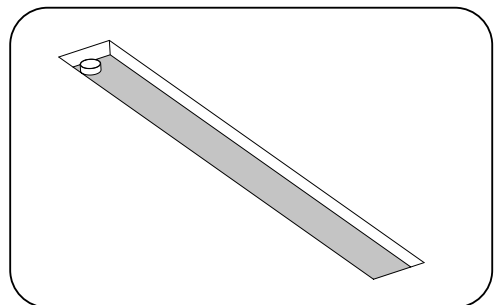

2. Lay a bed of C25 strength mixed concrete 100mm deep filling the entire base of the prepared trench.

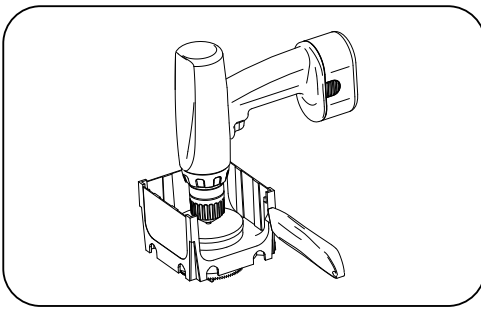

3. Prepare a Slot Drain Junction Unit by removing the necessary side with a knife and cutting an 80mm diameter hole in the base with a hole saw (if required).

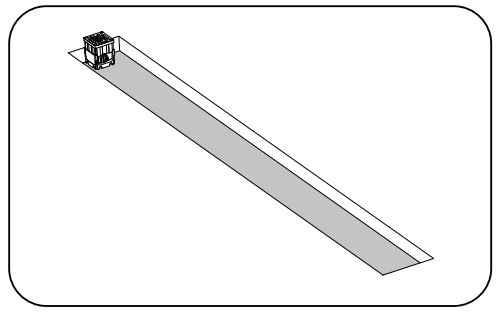

4. Starting above the drain outlet, position the junction unit over the outlet pipe and place a leaf trap in the prepared hole.

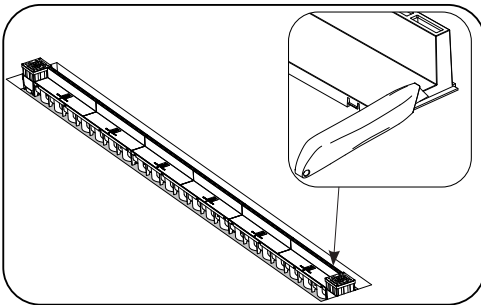

5. Working from the outlet, lay the lengths of SlotDrain, placing a prepared Junction Unit at 3m intervals and finishing the run with a Junction Unit. It is necessary to remove the end tab on the last SlotDrain grate next to a Junction Unit. See illustration above.

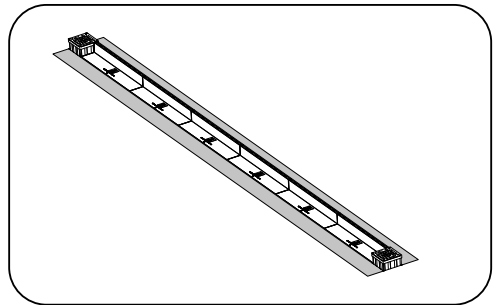

6. Surround both sides of the SlotDrain with a 100mm of C25 strength concrete, laid up to the top of the channel. Before surrounding the channel in concrete, ensure the slot grate is fully clipped into position for an even fit.

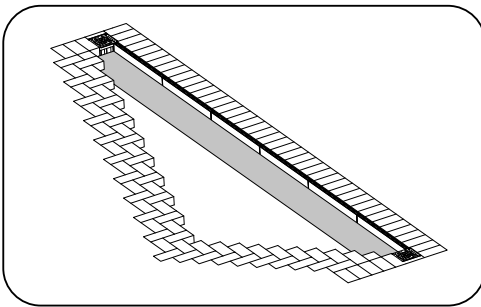

7. Pave around the SlotDrain, bonding the pavers which are in immediate contact with the drain itself or the concrete bed surrounding it. Ensure that the finished level of the paving is 3mm higher than the SlotDrain.

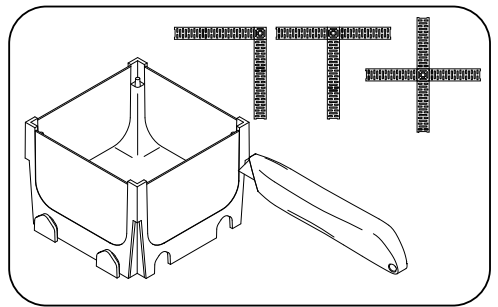

8. SlotDrain Junction Units can also be cut to create 90 degree corners, T-junctions and 4 way junctions as shown above.